

Gas Discharge Tube: GS2 Series

SMD L3.2 x W1.6 x H1.6 mm Type



■ Features

1. RoHS & HF compliant
2. SMD structure
3. DC spark-over voltage: 150~600V
4. Low capacitance
5. Agency recognition: UL
6. Operating temperature: -40°C ~ +105°C
Storage temperature: -40°C ~ +115°C

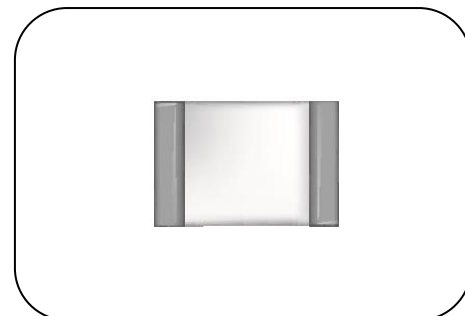

■ Recommended Applications

1. Cable modem
2. xDSL
3. Set-top box
4. TV sets
5. Ethernet port
6. Consumer electronics

■ Part Number Code

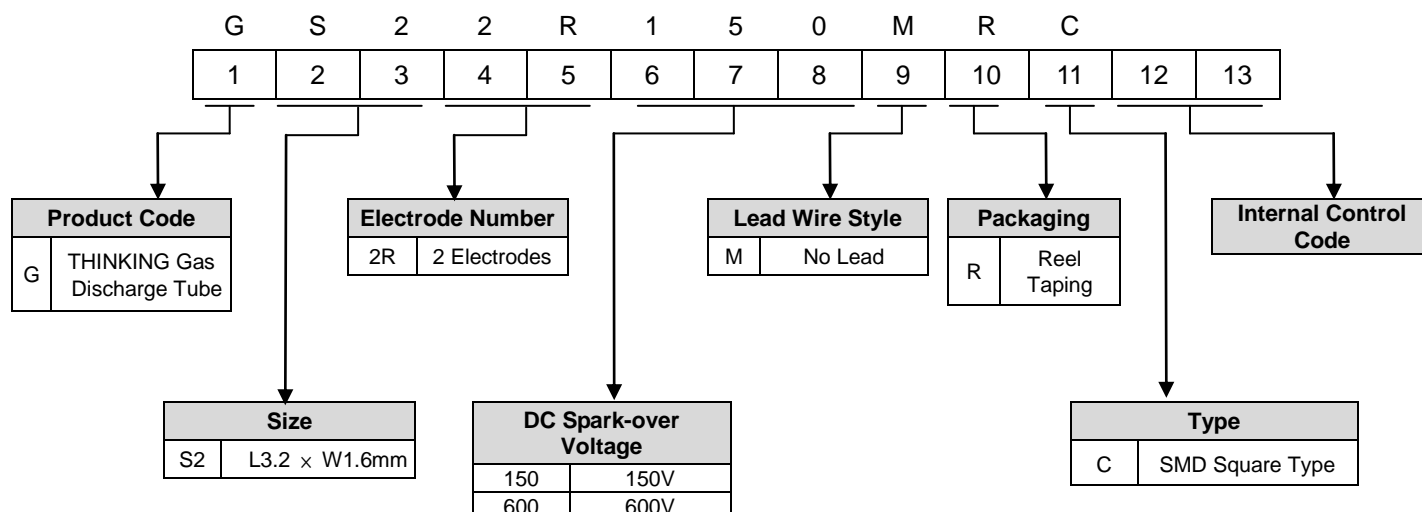

Gas Discharge Tube: GS2 Series

SMD L3.2 x W1.6 x H1.6 mm Type



■ Characteristics

Part No.	DC Spark-over Voltage	Max. Impulse Discharge Current	Impulse Withstanding Voltage Capacity	Normal Alternating Discharge Current	Impulse Life	Minimum Insulation Resistance	Maximum Capacitance	Safety Approvals
	100V/S	8/20 μ s	10/700 μ s	50Hz, 1 Sec	8/20 μ s, 50A			
	(V)	(A)	(KV)	(A)	(Times)			
GS22R150MRC	105~195	500A (Positive/ Negative 5 Times)	6KV R=40 Ω (Positive/ Negative 5 Times)	0.5A 10 Times	300	Min. 100 (@DC 100V)	0.3	UL 1449
GS22R200MRC	140~260							√
GS22R400MRC	280~520							√
GS22R420MRC	294~546							√
GS22R500MRC	350~650							√
GS22R600MRC	420~780							√

Note1: UL 1449 4th File No: E314979

Note2: Insulation resistance test condition:

DC Spark-over Voltage	DC Measuring Voltage
150-600V	100V

■ Dimension

(Unit: mm)

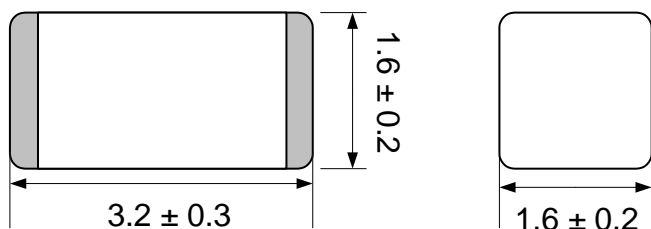

■ Recommended Pad Size

(Unit: mm)

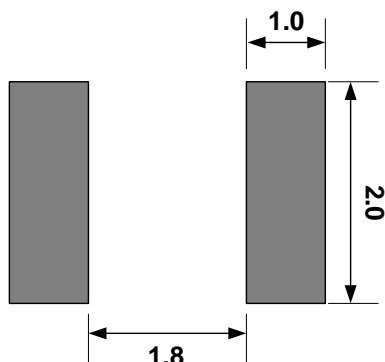

Gas Discharge Tube: GS2 Series

SMD L3.2 x W1.6 x H1.6 mm Type



■ Packaging

● Taping

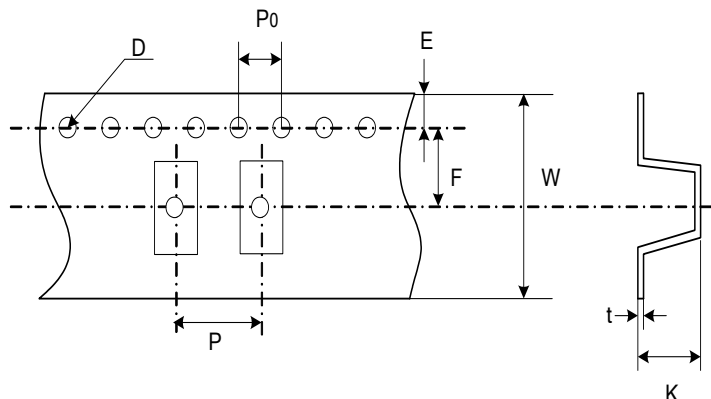

Quantity (MPQ): 3,000pcs

(Unit: mm)

Item	P	P0	W	F	E	D	K	t
Spec.	8.0	4.0	12.0	5.45	1.75	Φ1.55	2.0	0.3
Tolerance	±0.1	±0.1	±0.3	±0.1	±0.1	±0.05	±0.1	±0.05

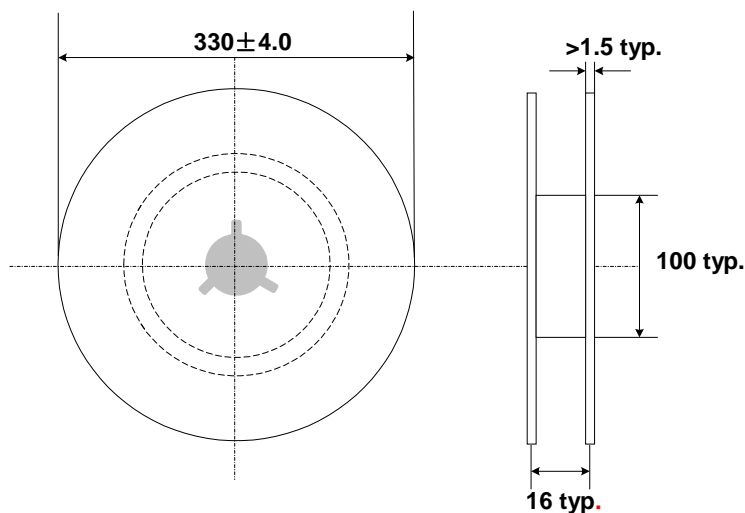

■ Warehouse Storage Conditions of Products

● Storage Conditions:

1. Storage Temperature: $-10^{\circ}\text{C} \sim +40^{\circ}\text{C}$
2. Relative Humidity: $\leq 75\% \text{RH}$
3. Keep away from corrosive atmosphere and sunlight.

● Period of Storage: 1 year